

Underground air valve system for sewage
Flange multi standard to EN 1092-2: 1997, BS 10-1947 and ASA, connections flange DN 80 or 100

Use:

For sewage to max. 60°C
 Instantaneous 90°C
 Working range: 0.2-10 bar

Options:

- One way attachment
- One way in, one way out
- Slow release (Anti-shock)

Standard feature:

Integral shut-off valve when dismantling the air valve for maintenance purposes.

All parts are corrosion resistant.

Materials:

Drainage outlet, air valve box, cover, drainage outlet, back flushing drainage assembly, drainage connection	Polypropylene
Coupling	PVC
Ball valve, bridge assembly	Stainless steel
Shut-off valve extension - spindle assembly, adaptor quick connection, T-key	Stainless steel
Seal plug assembly	Reinforced nylon, EPDM, stainless steel
Float	Foamed polypropylene
Body, base	Reinforced nylon / Stainless steel
Flange	Reinforced nylon
Knife shut-off valve	Ductile iron, stainless steel, EPDM



AIR AND VACUUM FLOW RATE

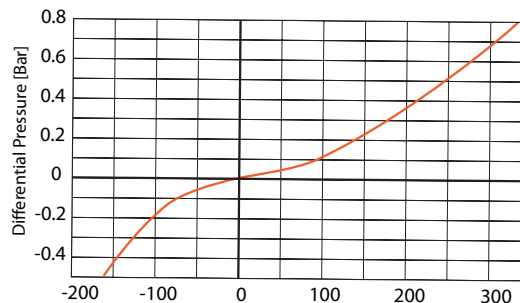

AUTOMATIC AIR DISCHARGE

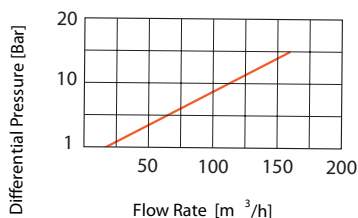

Underground air valve system for sewage
 Flange multi standard to EN 1092-2: 1997, BS 10-1947 and ASA, connections flange DN 80 or 100

Component list:

1. Drainage outlet
2. Coupling
3. Cover
4. Air valve box
5. Drainage outlet
6. Ball valve
7. Shut-off valve extension
Spindle assembly
8. Ball valve
9. Seal plug assembly
10. Float
11. Bridge assembly
12. Back flushing drainage assembly
13. Body
14. Base
15. Float
16. Adaptor - quick connection
17. Knife shut-off valve
18. Flange
19. Drainage connection
20. T-key

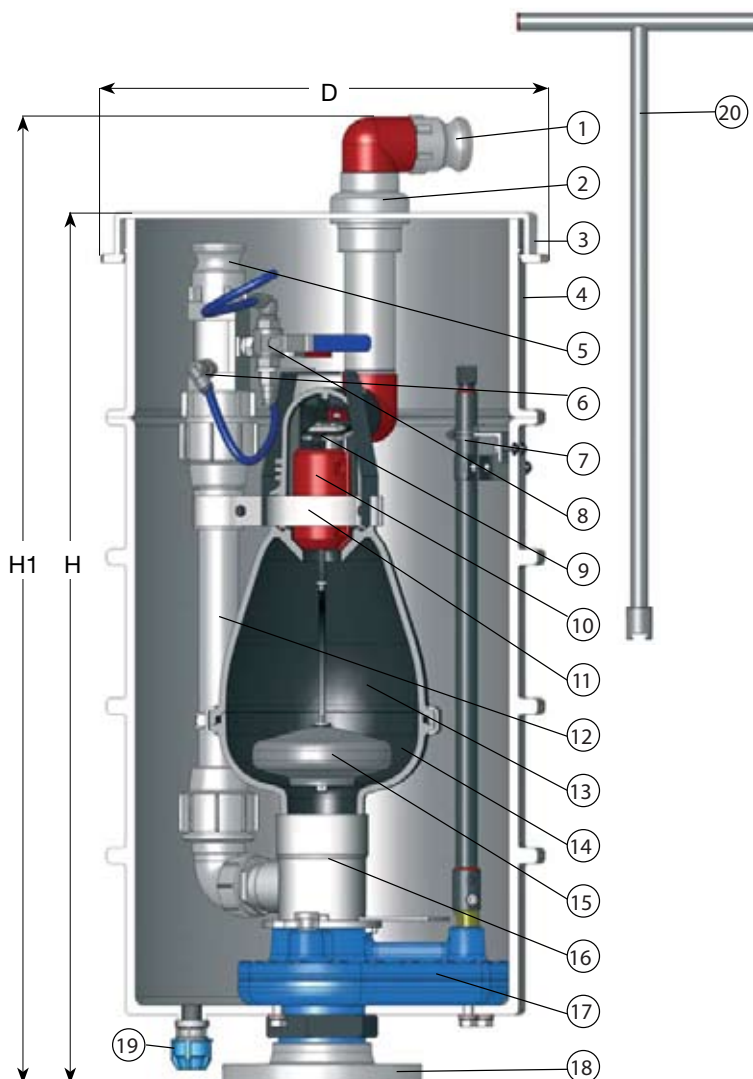

Ref. nos.	DN	Material	D mm	H mm	H1 mm	Weight kilos
701-080-79190010	3" thread	nylon	450	876	975	38,4
701-080-79190013	3" flanged	nylon	450	876	975	38,4
701-100-79190013	4" flanged	nylon	450	876	975	38,4
701-081-79190010	3" thread	Stainless steel	450	876	975	38,4
701-081-79190013	3" flanged	Stainless steel	450	876	975	38,4
701-100-79190013	4" flanged	Stainless steel	450	876	975	38,4
701-082-79190010	3" thread	nylon	450	1080	1175	39,0
701-083-79190013	3" flanged	nylon	450	1080	1175	39,0
701-102-79190013	4" flanged	nylon	450	1080	1175	39,0
701-083-79190010	3" thread	Stainless steel	450	1080	1175	39,0
701-082-79190013	3" flanged	Stainless steel	450	1080	1175	39,0
701-103-79190013	4" flanged	Stainless steel	450	1080	1175	39,0